

Great  
Science  
Share  
for SCHOOLS

# Great Glider Share 11-14 years

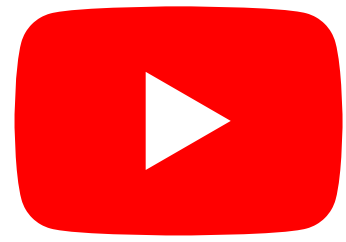

# Aerospace engineer – what do they do?



**Link to an introduction  
to the enquiry**

<https://youtu.be/NtGZh2EektE>



**Dr Ben Parslew  
Aerospace Engineer**



# Similarities and Differences



*image credit: Regiegeige*



*image credit: NASA*

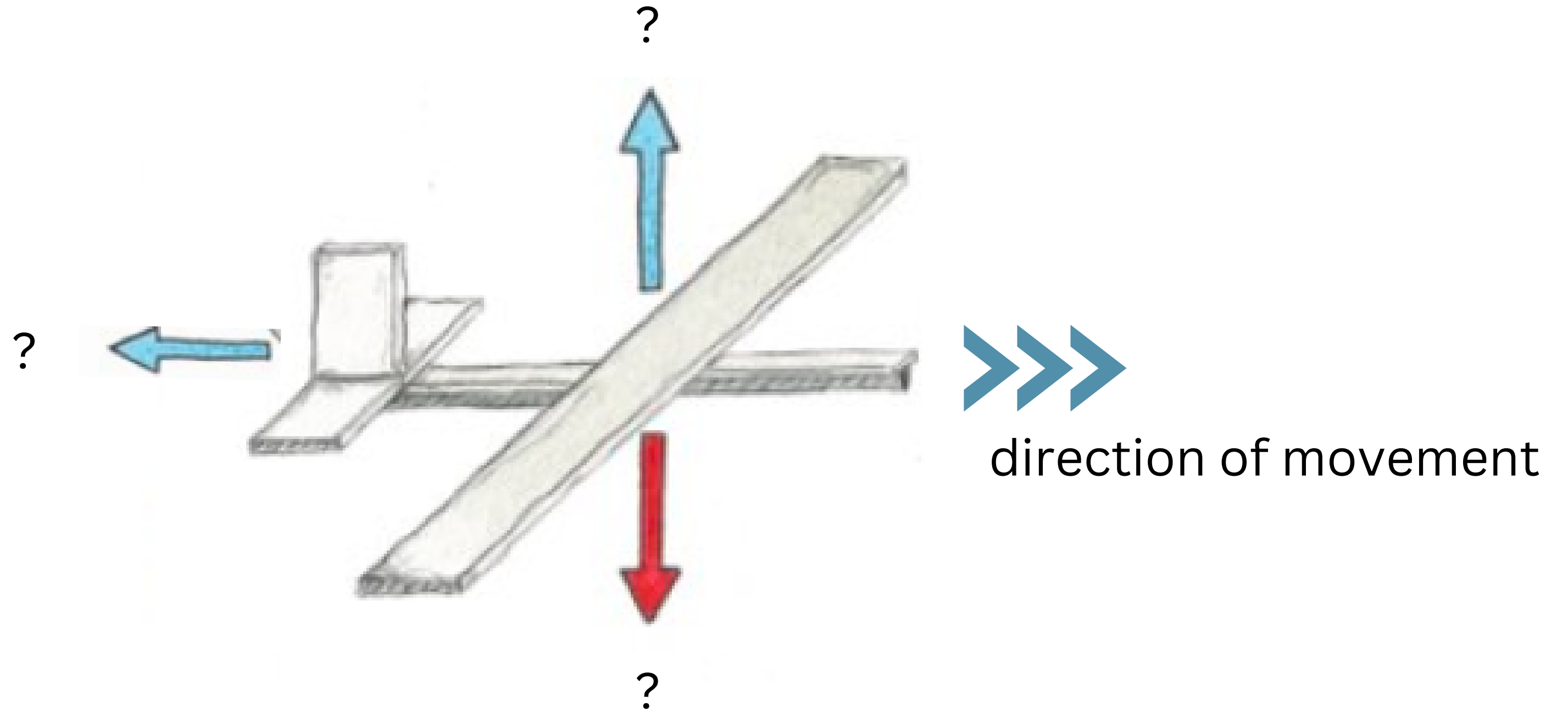

*image credit: Eric Salard*



*image credit: Balon Greyjoy*

# Glider Forces



Weight due to gravity

Drag

Lift

# Glider Forces

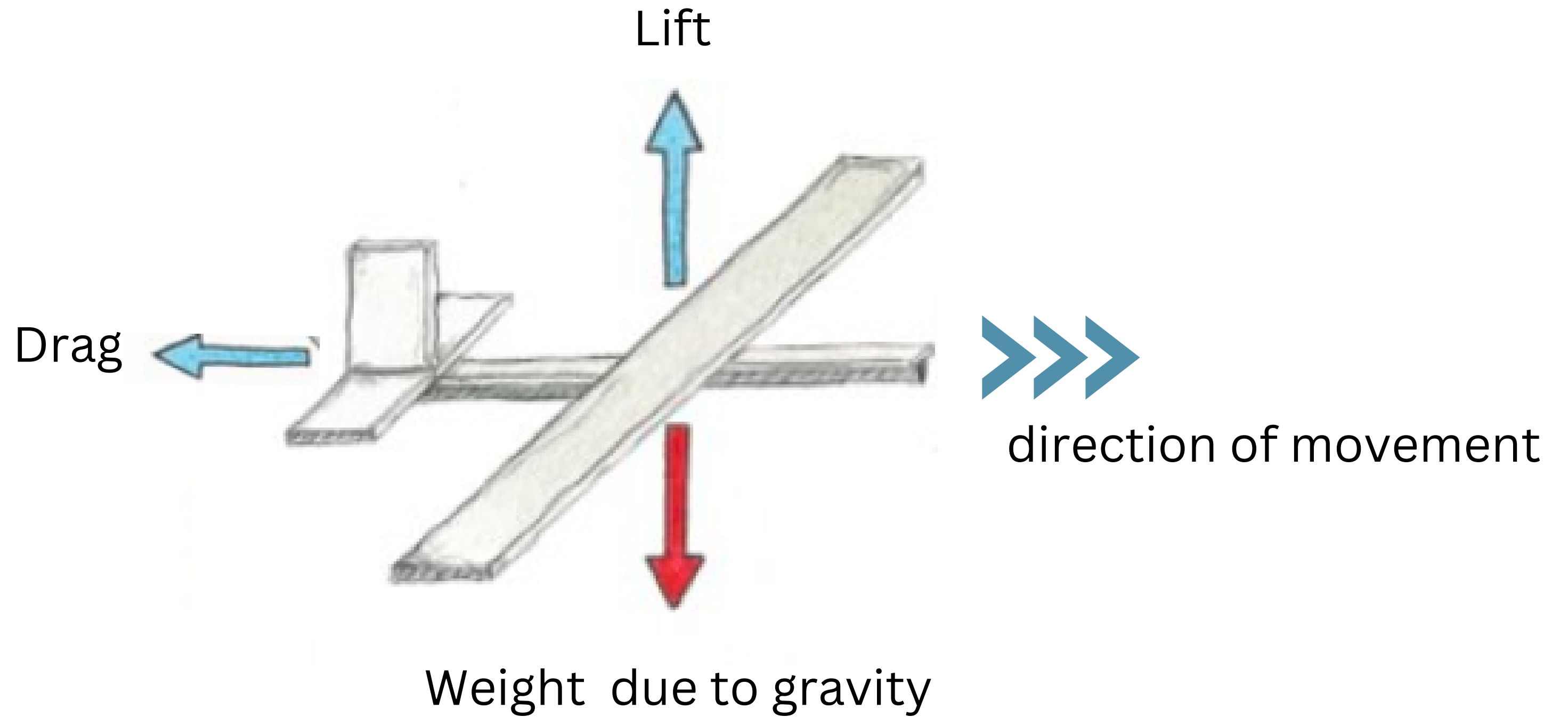



# Describe the centre of gravity, and how can you find it?

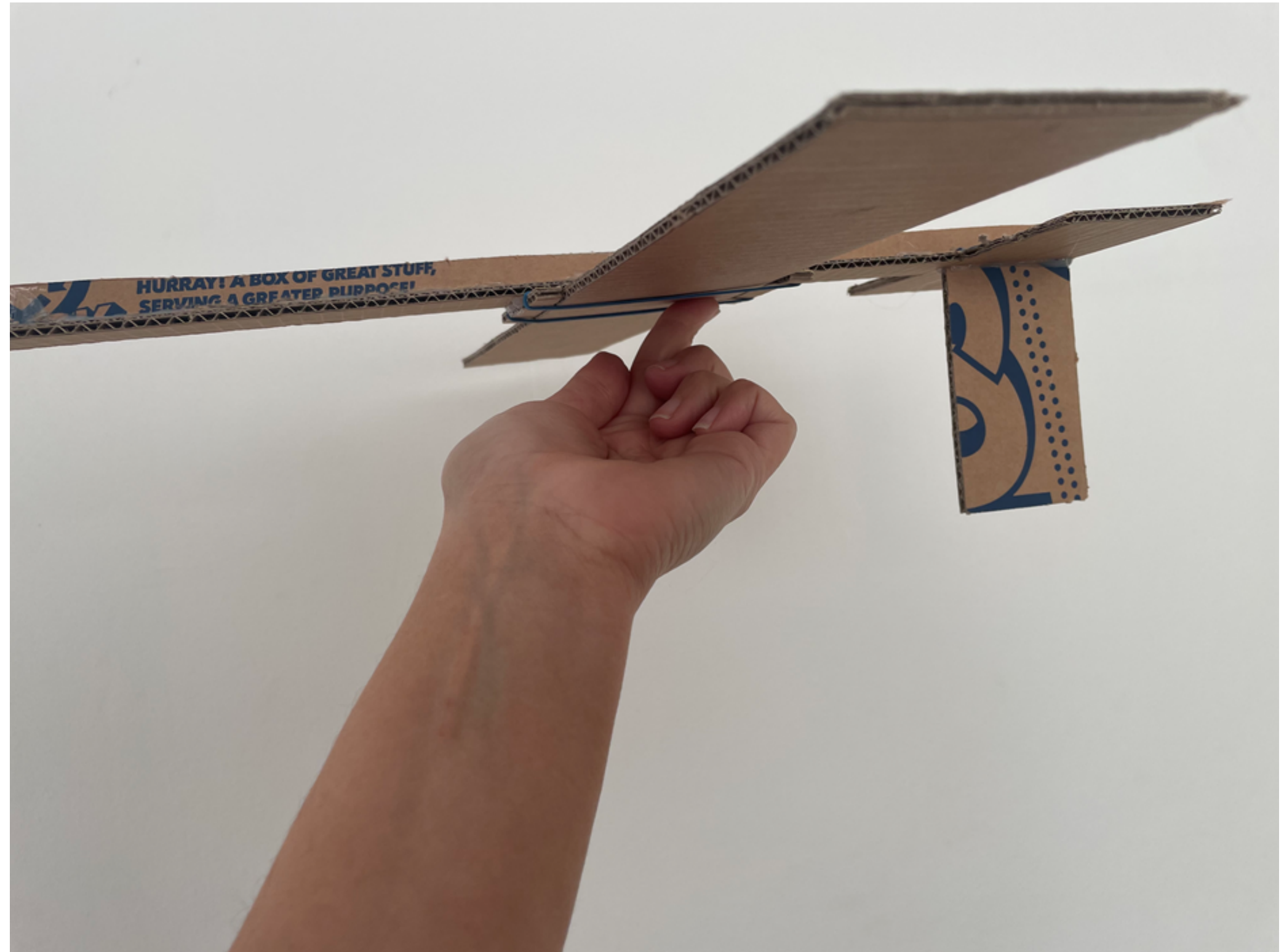

# What difference does the position of the ballast weight have on the distance a glider flies?



**We think...**

**because...**

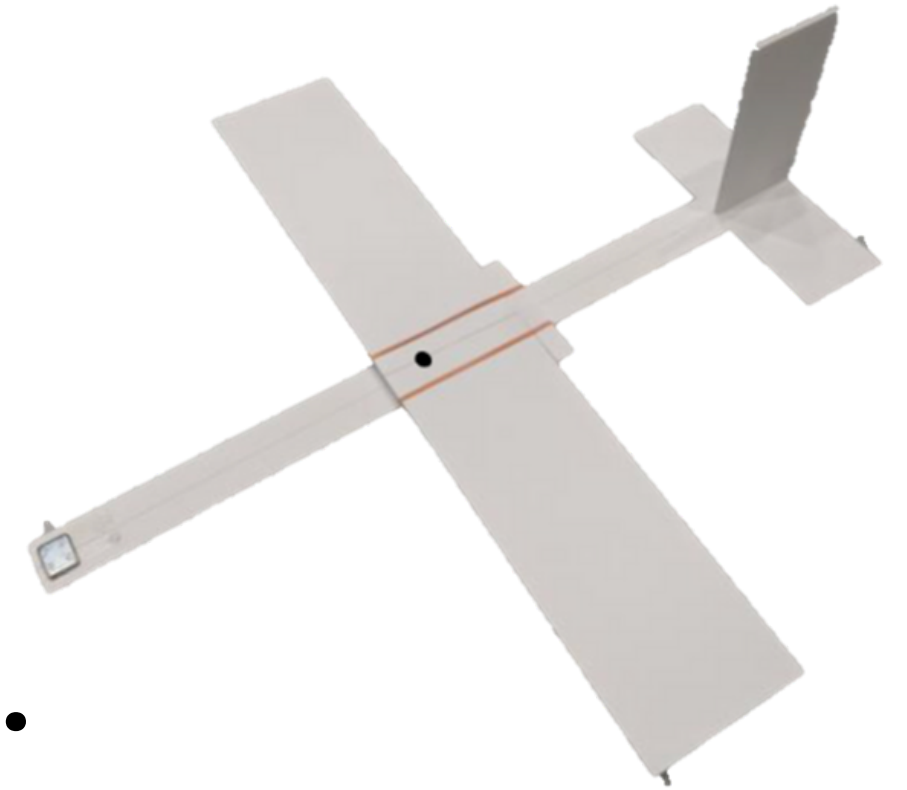

# The art of glider travel

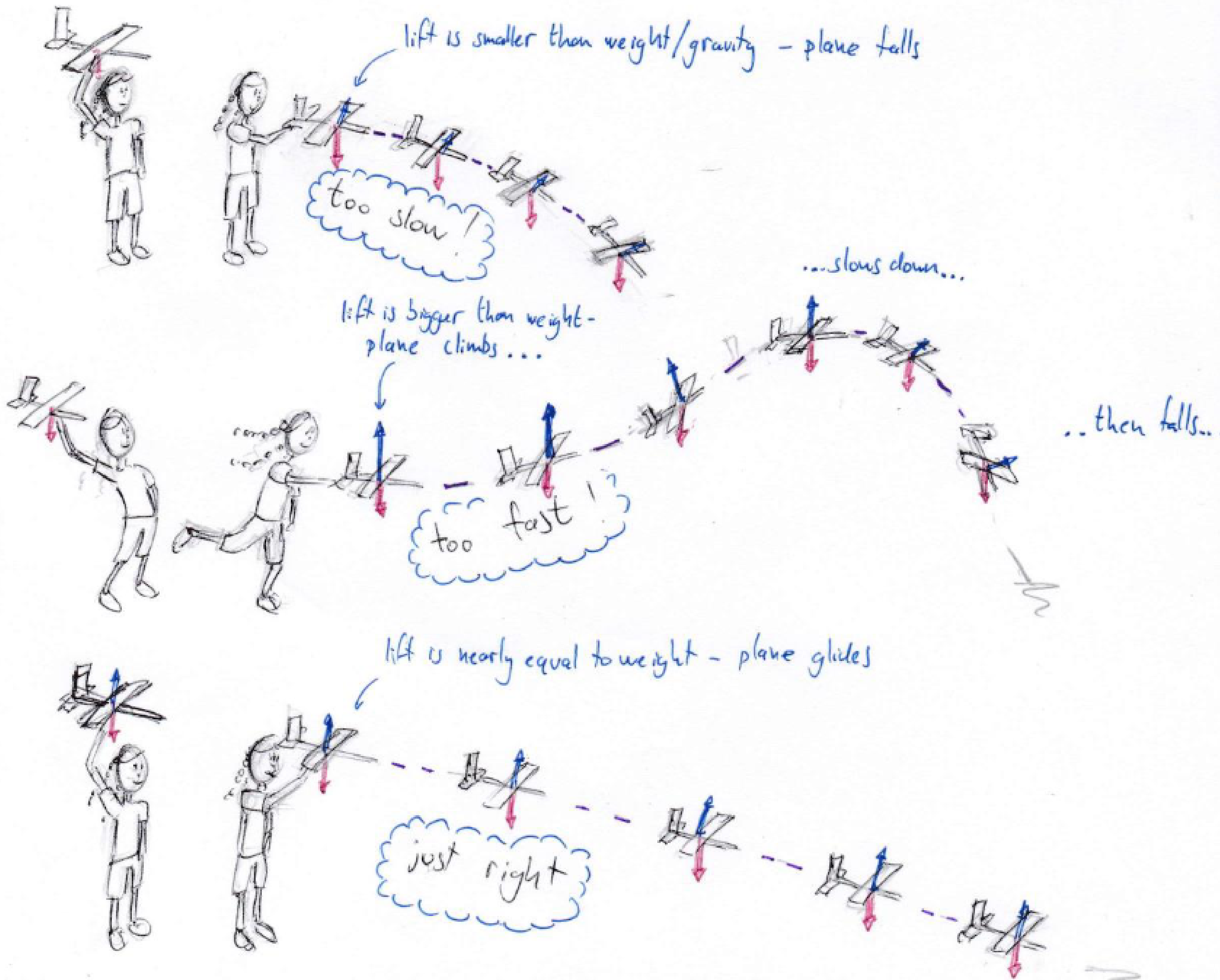





**Share your findings in a  
style of your choice to  
Dr Ben Parslew -  
Aerospace Engineer**



@GreatSciShare



# Is flight sustainable for future travel?

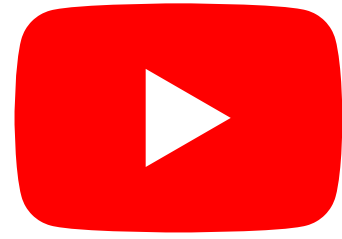

**Link to the video to  
find out more**

<https://youtu.be/nHjaBiW9ibc>





**Questioning**





# With special thanks to The Ogden Trust and The University of Manchester



**DISCLAIMER:** This activity sheet was written for The Great Science Share for Schools. The author(s) and the Great Science Share for Schools are not liable for the actions or activity of any persons who use this resource or in any of the suggested further resources. We assume no liability with regard to injuries or damage to property that may occur as a result of using this information. These activities are designed to be carried out by pupils working with an adult. The adult is fully responsible for ensuring the activity is carried out safely. You can access further Health & Safety guidance from CLEAPSS [www.cleapss.org.uk](http://www.cleapss.org.uk). and SSERC [www.sserc.org.uk](http://www.sserc.org.uk) (c) Copyright 2023 The University of Manchester